



DEPARTMENT OF REGULATORY AND ECONOMIC RESOURCES (RER)
BOARD AND CODE ADMINISTRATION DIVISION

MIAMI-DADE COUNTY
PRODUCT CONTROL SECTION
11805 SW 26 Street, Room 208
Miami, Florida 33175-2474
T (786) 315-2590 F (786) 315-2599
www.miamidade.gov/economy

NOTICE OF ACCEPTANCE (NOA)

Tejas Verea, S.A.
Lanza S/N 15685
Mesia (Coruña) Spain

SCOPE:

This NOA is being issued under the applicable rules and regulations governing the use of construction materials. The documentation submitted has been reviewed and accepted by Miami-Dade County RER - Product Control Section to be used in Miami Dade County and other areas where allowed by the Authority Having Jurisdiction (AHJ).

This NOA shall not be valid after the expiration date stated below. The Miami-Dade County Product Control Section (In Miami Dade County) and/or the AHJ (in areas other than Miami Dade County) reserve the right to have this product or material tested for quality assurance purposes. If this product or material fails to perform in the accepted manner, the manufacturer will incur the expense of such testing and the AHJ may immediately revoke, modify, or suspend the use of such product or material within their jurisdiction. RER reserves the right to revoke this acceptance, if it is determined by Miami-Dade County Product Control Section that this product or material fails to meet the requirements of the applicable building code.

This product is approved as described herein, and has been designed to comply with the Florida Building Code including the High Velocity Hurricane Zone of the Florida Building Code.

DESCRIPTION: Verea “Spanish S” Grade 1

LABELING: Each unit shall bear a permanent label with the manufacturer's name or logo, city, state and following statement: "Miami-Dade County Product Control Approved", unless otherwise noted herein.

RENEWAL of this NOA shall be considered after a renewal application has been filed and there has been no change in the applicable building code negatively affecting the performance of this product.

TERMINATION of this NOA will occur after the expiration date or if there has been a revision or change in the materials, use, and/or manufacture of the product or process. Misuse of this NOA as an endorsement of any product, for sales, advertising or any other purposes shall automatically terminate this NOA. Failure to comply with any section of this NOA shall be cause for termination and removal of NOA.

ADVERTISEMENT: The NOA number preceded by the words Miami-Dade County, Florida, and followed by the expiration date may be displayed in advertising literature. If any portion of the NOA is displayed, then it shall be done in its entirety.

INSPECTION: A copy of this entire NOA shall be provided to the user by the manufacturer or its distributors and shall be available for inspection at the job site at the request of the Building Official.

This NOA revises NOA# 19-0513.06 and consists of pages 1 through 8.

The submitted documentation was reviewed by *Freddy Semino*



NOA No.: 20-0902.02
Expiration Date: 03/13/23
Approval Date: 12/31/20
Page 1 of 8

ROOFING ASSEMBLY APPROVAL

Category: Roofing
Sub Category: Roofing Tiles
Material: Clay

1. SCOPE

This approves a roofing system using Verea “Spanish S” Grade 1 manufactured by Tejas Verea, S.A. in La Coruna, Spain and is distributed by Ceramica Verea, USA Corp., as described in Section 2 of this Notice of Acceptance. For locations where the pressure requirements, as determined by applicable Building Code does not exceed the design pressure values obtained by calculations in compliance with RAS 127 using the values listed in section 4 herein. The attachment calculations shall be done as a moment based system.

2. PRODUCT DESCRIPTION

<u>Manufactured by</u> <u>Applicant</u>	<u>Dimensions</u>	<u>Test</u> <u>Specifications</u>	<u>Product</u> <u>Description</u>
Verea “Spanish S” Grade 1	L = 19.5” W = 10.85” H = 2.8”	ASTM C1167 Type I Grade 1	High profile clay roof tile. For direct deck, adhesive set applications.
Trim Pieces	Length: varies Width: varies varying thickness	ASTM C1167	Accessory trim, clay roof pieces for use at hips, rakes, ridges and valley terminations manufactured for each tile profile.
Verea Hurricane Clip	2.95” x 0.47” x 0.09” diam.		(Optional) stainless steel clip.

2.1 MANUFACTURING LOCATION

2.1.1. Mesia (La Coruña) Spain



2.2 EVIDENCE SUBMITTED

<u>Test Agency</u>	<u>Test Identifier</u>	<u>Test Name/Report</u>	<u>Date</u>
American Test Lab of South Florida	RT0202.02-18	ASTM C 1167	02/10/18
	RT0621.01-16	ASTM C 1167	09/09/16
	RT0311.01-14	TAS 101	03/18/14
	RT0609.01-20	TAS 101	06/12/20
	RT0616.01-20	ASTM C 1167	06/23/20
IBA Consultants, Inc.	4709-3	TAS 101	12/21/07
PRI Construction Materials Technologies	CVER-013-02-01	TAS 101	12/30/13
	CVER-014-02-01	TAS 102	03/11/14
	CVER-015-02-01	TAS 100	04/07/14
Redland Technologies	7161-03 Appendix III P0402	PA 102 & PA 102(A) Withdrawal Resistance Testing of screw vs. smooth shank nails	Dec. 1991 Sept. 1993
The Center for Applied Engineering, Inc.	25-7094-(3, 6 & 9)	PA 102	Oct. 1994
	25-7120-(1 & 2)	PA 102	Nov. 1994
	25-7183-(3 & 4)	PA 102	Feb. 1995
	25-7214-(3, 4, &7)	PA 102	March, 1995
	25-7804-4	PA 102	Sep. 1996



3. LIMITATIONS:

- 3.1 Fire classification is not part of this acceptance.
- 3.2 For mortar or adhesive set tile applications, a static field uplift test in accordance with TAS 106 may required, refer to applicable building code.
- 3.3 Applicant shall retain the services of a Miami-Dade County Certified Laboratory to perform quarterly test in accordance with TAS 112, appendix 'A'. Such testing shall be submitted to the Regulatory and Economic Development Department – Product Control Section for review.
- 3.4 Minimum underlayment shall be in compliance with the applicable Roofing Applications Standards listed section 4.1 herein.
- 3.5 30/90 hot mopped underlayment applications may be installed perpendicular to the roof slope unless stated otherwise by the underlayment material manufacturers published literature.
- 3.6 This acceptance is for wood deck applications. Minimum deck requirements shall be in compliance with applicable building code.

4. INSTALLATION

- 4.1 Verea “Spanish “S” Grade 1 and its components shall be installed in strict compliance with Roofing Application Standard RAS 118, RAS 119, and RAS 120.
- 4.2 Data For Attachment Calculations.

Table 1: Average Weight (W) and Dimensions (l x w)			
Tile Profile	Weight-W (lbf)	Length-l (ft)	Width-w (ft)
Verea “Spanish S” Grade 1	8.0	1.625	0.904

Table 2: Aerodynamic Multipliers - λ (ft³)		
Tile Profile	λ (ft³) Batten Application	λ (ft³) Direct Deck Application
Verea “Spanish S” Grade 1	N/A	0.31

Table 3: Restoring Moments due to Gravity - M_g (ft-lbf)						
Tile Profile	2":12"	3":12"	4":12"	5":12"	6":12"	7":12" or Greater
Verea “Spanish S” Grade 1	Direct Deck 6.46	Direct Deck 6.36	Direct Deck 6.21	Direct Deck 6.01	Direct Deck 5.74	Direct Deck 5.40



Table 4: Attachment Resistance Expressed as a Moment - M_f (ft-lbf) for Mechanically Attached Systems				
Tile Profile	Fastener Type	Direct Deck (min 15/32" plywood)	Direct Deck (min. 19/32" plywood)	Battens
Verea "Spanish S" Grade 1	2-10d Ring Shank Nails	28.6	41.2	n/a
	1-10d Smooth or Screw Shank Nail	5.1	6.8	n/a
	2-10d Smooth or Screw Shank Nails	6.9	9.2	n/a
	1 #8 Screw	20.7	20.7	n/a
	2 #8 Screw	43.2	43.2	n/a
	1-10d Smooth or Screw Shank Nail (Field Clip)	23.1	23.1	n/a
	1-10d Smooth or Screw Shank Nail (Eave Clip)	29.3	29.3	n/a
	2-10d Smooth or Screw Shank Nails (Field Clip)	27.6	27.6	n/a
2-10d Smooth or Screw Shank Nails (Eave Clip)	38.1	38.1	n/a	

Table 5: Attachment Resistance Expressed as a Moment - M_f (ft-lbf) for Mechanically Attached Systems				
Tile Profile	Fastener Type	Direct Deck (min 15/32" plywood)	Direct Deck (min. 19/32" plywood)	Battens
Verea "Spanish S" Grade 1	2-10d Ring Shank Nails ¹	33.1	48.1	n/a
1 Installation with a 4" tile headlap and fasteners are located a min. of 2½" from head of tile.				

Table 6: Attachment Resistance Expressed as a Moment - M_f (ft-lbf) for Single Patty Adhesive Set Systems		
Tile Profile	Tile Application	Minimum Attachment Resistance
Verea "Spanish S" Grade 1	ICP Adhesives Polyset AH-160	63.212 ¹
	ICP Adhesives Polyset AH-160	58.6 ²
	TILE BOND Roof Tile Adhesive	53.9 ³
1	Large paddy placement weight 34.6 grams of ICP Adhesives and Sealants, Inc.'s ICP Adhesives Polyset AH-160.	
2	Medium paddy placement weight 24.5 grams of ICP Adhesives and Sealants, Inc.'s ICP Adhesives Polyset AH-160	
3	Large paddy placement weight 27.5 grams of Tile Bond Roof Tile Adhesive	



5. LABELING

5.1 All tiles shall bear the imprint or identifiable marking of the manufacturer's name or logo as detailed below, or following statement: "Miami-Dade County Product Control Approved".

VEREA SPAIN CE

**LABEL FOR VERA "SPANISH S" GRADE 1
(LOCATED ON THE SIDE OF TILE)**

6. BUILDING PERMIT REQUIREMENTS:

6.1 Application for building permit shall be accompanied by copies of the following:

6.1.1 This Notice of Acceptance.

6.1.2 Any other documents required by Building Official or Applicable building code in order to properly evaluate the installation of this system.



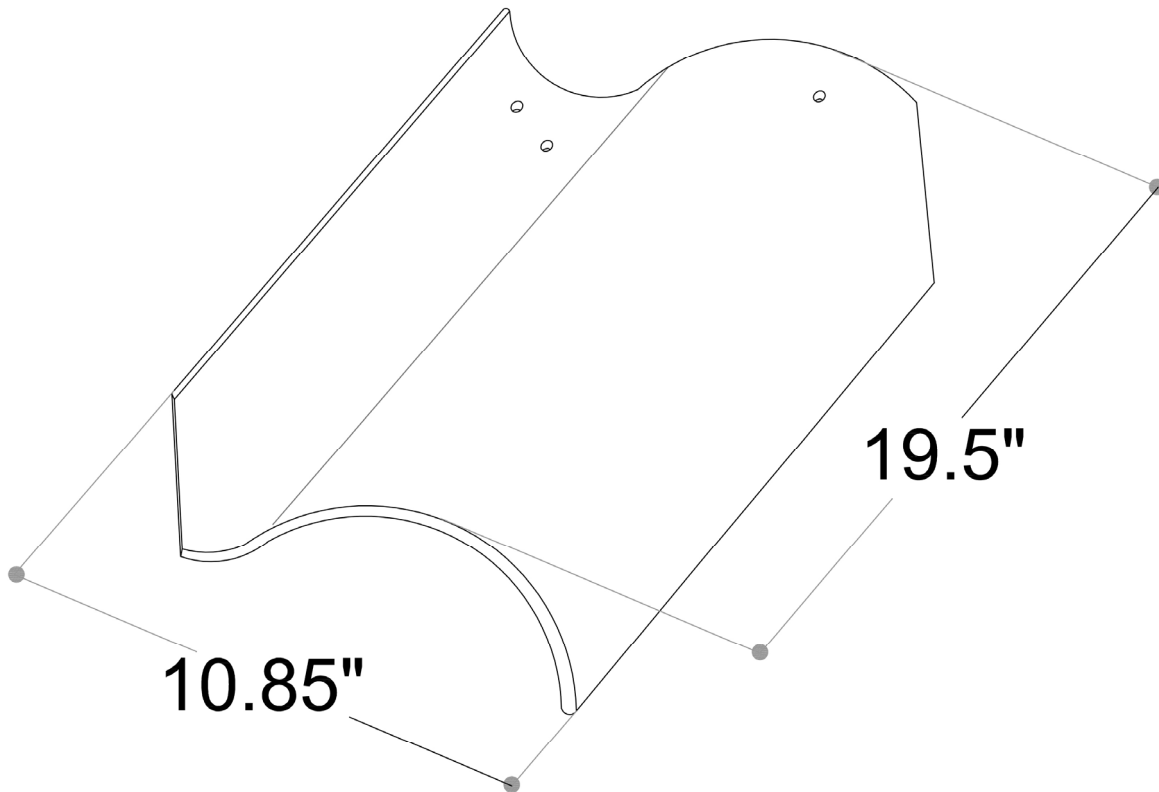

VEREA "SPANISH S" GRADE 1



VEREA HURRICANE CLIP

NOTE: USE OF CLIP IS OPTIONAL. REFER TO MANUFACTURERS PUBLISHED INSTRUCTIONS FOR INSTALLATION DETAIL

END OF THIS ACCEPTANCE



**GREEN SUSTAINABLE ATTRIBUTES
(GSA)**

SCOPE: This document is solely for the purpose of verification of Sustainable Attributes of construction materials. The documentation submitted has been reviewed by Miami-Dade County Product Control Section.

G.1 - SOLAR REFLECTANCE AND THERMAL EMMITANCE

<u>Component Name</u>	<u>Initial Reflectance</u>	<u>Aged Reflectance</u>	<u>Initial Emittance</u>	<u>Aged Emittance</u>	<u>Solar Reflectance Index (SRI)</u>
1. Verea "Spanish S" Clay Roof Tile Grade 1	0.39	Pending	0.83	Pending	41

G.2 - THERMAL RESISTANCE

<u>R-Value</u>	<u>Insulation / Thickness</u>	<u>Assemblies:</u>
2.09	0.46	Verea "Spanish S" Clay Roof Tile Grade 1

G.3 - LOW VOC COMPONENTS

<u>Component Name</u>	<u>Content</u>	<u>Emission</u>
1. Verea "Spanish S" Clay Roof Tile Grade 1	0% COV's	0%

G.4 - RECYCLED CONTENT / BIO-BASED MATERIAL / RAPIDLY RENEWABLE MATERIAL

<u>Component Name</u>	<u>% Recycled Content at Manuf.</u>	<u>% Recycled at Disposal</u>	<u>% Bio-based Material</u>	<u>% Renewable Material</u>
1. Verea "Spanish S" Clay Roof Tile Grade 1	20%			100%

G.6 - ROOF SYSTEM LIFE CYCLE

<u>Years</u>	<u>Assemblies:</u>
150	Verea "Spanish S" Clay Roof Tile Grade 1

G.7 - REGIONALLY MANUFACTURED COMPONENTS

<u>Component Name</u>	<u>Manufacturing Location</u>
1. Verea "Spanish S" Clay Roof Tile Grade 1	Quarry-Crucero 22 Frades; quartz extracted in surrounding councils Mesía/Frades (La Coruña)- Spain. Local extraction less than 5 km

